



ART. 3100IP

TRACCIATO TECNICO COSTRUTTIVO

- Sollevatore oleopneumatico a carrello.
- Indicato per il sollevamento di autovetture, SUV, veicoli commerciali e industriali.
- Design completamente innovativo.
- Punto presa super ribassato.
- Manico ergonomico.
- Supporto piattello a base ampia.
- Piattello in acciaio.
- Ruote in nylon.

TECHNICAL AND STRUCTURAL LAY-OUT

- Air-hydraulic trolley jack.
- Suggested to lift cars, SUV, commercial vehicles and medium lorries.
- Completely innovative design.
- Very low profile.
- Ergonomic handle.
- Support holder with wide base.
- Stainless steel support.
- Nylon wheels.

RELEVÉ TECHNIQUE

- Cric rouleur oléopneumatique.
- Conseillé pour le levage de voitures, tout-terrains et poids moyens.
- Innovation du design.
- Point de prise surbaissé.
- Manche ergonomique.
- Support plateau à base large.
- Plateau acier.
- Roues en nylon.

TECHNISCHE UND KONSTRUKTIVE ANGABEN

- Hydropneumatischer Rangierheber.
- Bezeichnet für SUV, Fahrzeuge, Nutzfahrzeuge und medium LKW.
- Völlig innovatives Design.
- Super abgeflachte Aufnahmepunkte.
- Ergonomische Zugstang.
- Tellerstütz mit weiter Grundlage.
- Stahlsteller.
- Nylonräder.

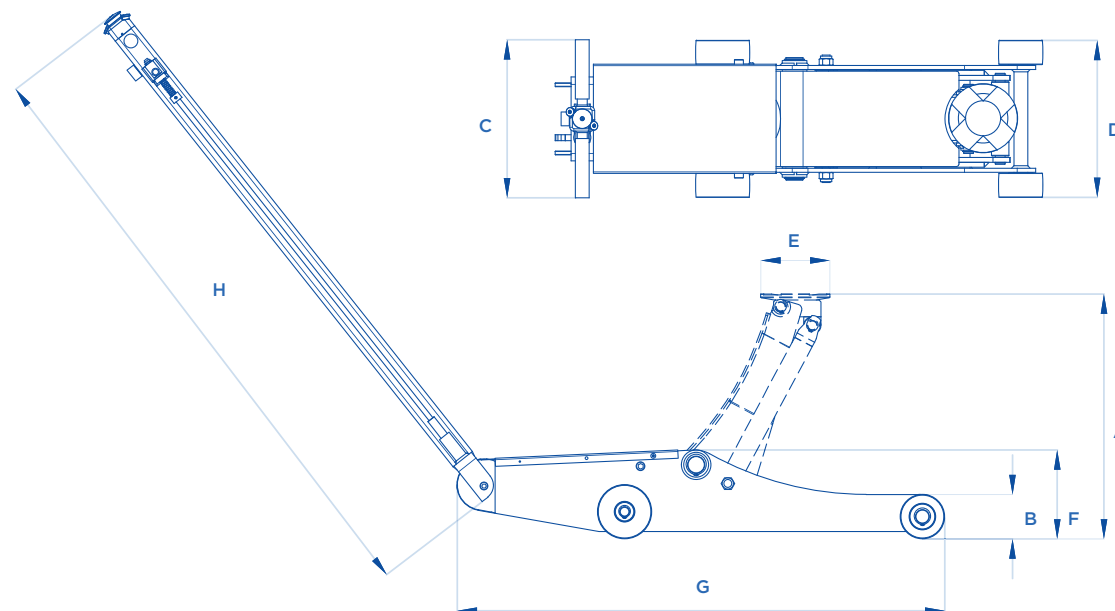

ART.			A mm	B mm	C mm	D mm	E mm	F mm	G mm	H mm	KG
3100IP	5000 kg	10 bar	500	90	320	320	140	180	970	1230	100

 Alimentazione pneumatica • Pneumatic feeding • Pression d'alimentation • Benötigter Luftdruck